

Technical data sheet



Product features

Steak grill electric double 65x48 table durable chrome

Model	SAP Code	00021115
KD 66 E	A group of articles - web	Grills and grill plates



- Top type: Smooth
- Griddle dimensions [mm x mm]: 650 x 480 + 320 x 380 + 320 x 380
- Griddle thickness [mm]: 10.00
- Worktop material: AISI 304
- Container for liquid fat: Yes
- Independent heating zones: Separate control for each heating zone on the bottom plate and for the top plates
- Maximum device temperature [°C]: 300
- Surface finish: durable chrome

SAP Code	00021115	Power electric [kW]	12.000
Net Width [mm]	710	Loading	230/400 V / 1/3N - 50 Hz
Net Depth [mm]	725	Griddle dimensions [mm x mm]	650 x 480 + 320 x 380 + 320 x 380
Net Height [mm]	540	Top type	Smooth
Net Weight [kg]	60.00		

Technical data sheet



Technical drawing

Steak grill electric double 65x48 table durable chrome

Model	SAP Code	00021115
KD 66 E	A group of articles - web	Grills and grill plates

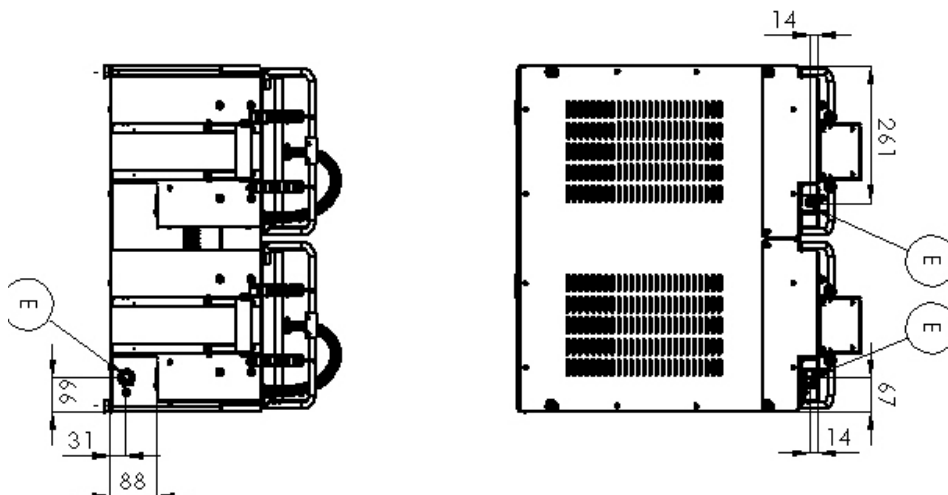
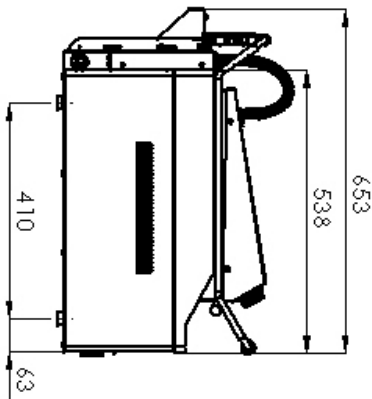
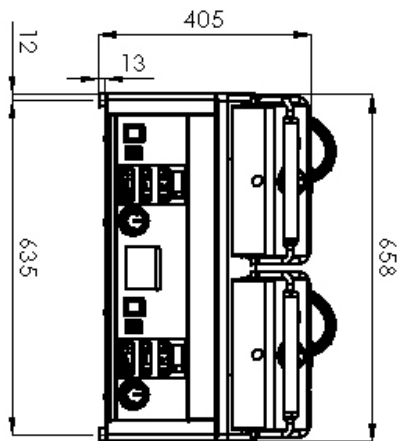

Technical data sheet



Product benefits

Steak grill electric double 65x48 table durable chrome

Model	SAP Code	00021115
KD 66 E	A group of articles - web	Grills and grill plates

1

Nationheres

Only stainless steel used for food contact

- Absolutely stainless steel and non -magnetic design resists even weaker acids easier to fill hygiene standards (HACCP); Simple maintenance and cleaning

2

Chrome 0.03mm

non -stick dishes when roasting easier to clean the board

- Faster and easier work to operate a higher quality of food

3

Self -controlled control for upper and lower heating

can i control both areas independent of each other

- Better adjustability and saving el. Energy more uniformly cooking I can prepare more types of meals and faster on one device

4

Upper contact area with Teflon canvas

non -backed rollers
uniform warming the rolls

- faster and easier work for service
- faster preparation
- maintaining the shape of food
- faster closed surface of food from both sides of more juicy meat

Technical data sheet



Technical parameters

Steak grill electric double 65x48 table durable chrome

Model	SAP Code	00021115
KD 66 E	A group of articles - web	Grills and grill plates

1. SAP Code:

00021115

2. Net Width [mm]:

710

3. Net Depth [mm]:

725

4. Net Height [mm]:

540

5. Net Weight [kg]:

60.00

6. Gross Width [mm]:

725

7. Gross depth [mm]:

710

8. Gross Height [mm]:

540

9. Gross Weight [kg]:

65.00

10. Device type:

Electric unit

11. Construction type of device:

Table top

12. Power electric [kW]:

12.000

13. Loading:

230/400 V / 1/3N - 50 Hz

14. Protection of controls:

IPX4

15. Material:

AISI 430

16. Indicators:

operation and warm-up

17. Worktop material:

AISI 304

18. Surface finish:

durable chrome

19. Maximum device temperature [°C]:

300

20. Minimum device temperature [°C]:

50

21. Griddle dimensions [mm x mm]:

650 x 480 + 320 x 380 + 320 x 380

22. Griddle thickness [mm]:

10.00

23. Container for liquid fat:

Yes

24. Independent heating zones:

Separate control for each heating zone on the bottom plate and for the top plates

25. Uniform heating:

Yes

26. Top type:

Smooth

27. Cross-section of conductors CU [mm²]:

10